

FPGA applications for single dish activity at Medicina radio telescopes

M. Bartolini, G. Naldi, A. Mattana, A. Maccaferri, and M. De Biaggi

Istituto Nazionale di Astrofisica – Istituto di Radioastronomia, Via P. Gobetti, 101, 40129 - Bologna, Italy, e-mail: bartolini@ira.inaf.it

Abstract. FPGA technologies are gaining major attention in the recent years in the field of radio astronomy. At Medicina radio telescopes, FPGAs have been used in the last ten years for a number of purposes and in this article we will take into exam the applications developed and installed for the Medicina Single Dish 32m Antenna: these range from high performance digital signal processing to instrument control developed on top of smaller FPGAs.

Key words. Radio Astronomy – FPGA – Digital Signal Processing

1. Introduction

The Medicina dish, whose first light dates back to 1983, is a 32-m parabolic antenna located 35 Km south-east of Bologna (Italy). It is managed by the Istituto di Radioastronomia (IRA), which is part of the Istituto Nazionale di Astrofisica (INAF).

The Medicina antenna is a 32-m parabolic dish with Cassegrain optical configuration, installed on an altazimuthal mount. Its two foci, the primary focus and the secondary (or Cassegrain) focus, host a total number of 7 receivers, which can be selected in frequency agility mode: the subreflector is remotely commanded to slide to the retracted position, and it takes less than four minutes to complete the primary to secondary focus switching (or vice versa).

The antenna, prior to the development of the Enhanced Single-dish Control System in the framework of the DISCOS project (Orlati et al. 2016), was operated using only the Field System (FS): the control software provided by



Fig. 1. The Medicina 32m dish

the VLBI Network. This software, though reliable and constantly updated, was conceived for interferometric observations substantially based on the position switching mode and was not optimized for single-dish activities requiring different observing strategies.

2. The need for FPGAs

As the antenna has been upgraded with the new ESCS control system, with enhanced single dish capabilities (Righini et al. 2014), also digital backends for data acquisition and recording need to be upgraded in order to perform total power revelation and spectro-polarimetric observations which cannot be achieved using standard VLBI instrumentation.

In this context, FPGA technologies have been used in many different ways and in this paper we take into exam two different approaches: the first is the utilization of FPGAs as high performance computing configurable engines, needed to perform real-time digital signal processing; the second main usage concerns the application of FPGAs to electronic instrumentation control, easing the development of complex electronic instrumentation and relaxing real-time PLC constraints.

DSP is of particular interest when we consider that the old standard VLBI processing modules used to digitize signals in the order of 8MHz bandwidth, while single dish astronomy requires bandwidths up to 2GHz to reach the necessary sensitivity. Analyzing 2GHz bandwidths, in terms of data rate, means that if we digitize the signal using 8 bits and sampling according to Nyquist law, we have to process a data stream of 4GB/sec. in real time. Considering that for each receiver we need to process two different polarizations, the sum goes up to 8GB/sec. and the need for special purpose hardware becomes obvious if we try to approach this problem taking into account other factors such as analogue and digital data I/O and recording, and costs.

2.1. Casper hardware

Since 2006 Medicina station is provided with some CASPER (casper collaboration 2009)

FPGA-based processing boards in order to fulfill the signal processing needs for several applications. ROACH1 and ROACH2 are the second generation of CASPER processing boards present at Medicina radio observatory. ROACH (Reconfigurable Open Architecture Computing Hardware) was developed thanks to a collaboration among SKA South Africa group (MeerKAT), UC Berkeley and NRAO (National Radio Astronomy Observatory). The ROACH1 board is equipped with a single Xilinx Virtex-5 XC5VSX95T FPGA. A separate PowerPC is used to control the board (program the FPGA and allow interfacing between the FPGA software registers/BRAMs/FIFOs and external devices using Ethernet). Two quad data rate (QDR) SRAMs provide high-speed, medium-capacity memory (specifically for doing corner-turns), and one DDR2 DIMM provides slower-speed, high-capacity buffer memory for the FPGA. Two Z-DOK connectors allow ADC, DAC and other interface cards to be attached to the FPGA. Four CX4 connectors provide a total of 40Gbits/sec bandwidth for connecting ROACH boards together, or connecting them to other XAUI/10GbE-capable devices. The Roach2 board is implemented with the same philosophy of Roach1 while adopting more recent technologies such as Xilinx Virtex-6 series of FPGAs and optical links for 10gbps connectivity implemented on mezzanine boards.

3. Medicina receiving chain

At Medicina station, each receiver on the dish performs a down conversion of the signal in the range 0.1GHz - 2.1GHz (or less, if not available) and transmits it to a first control unit in the Vertex room, right below the dish focus.

Signal is then multiplexed via a selector which forwards to the processing units situated in the control room via RF over fiber. The correct signal is selected in the Vertex room by the control system which knows which receiver is actually being used. Optical receivers perform a final trasduction of the signal in the ground control unit, feeding the sampling stages of the digital and analogue back-ends for signal elaboration.

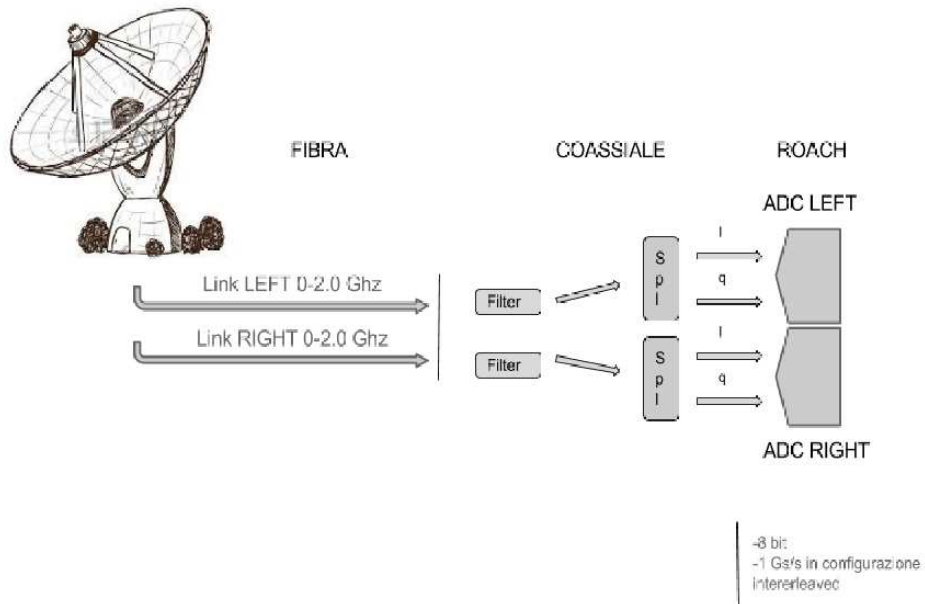

Fig. 2. Medicina signal path

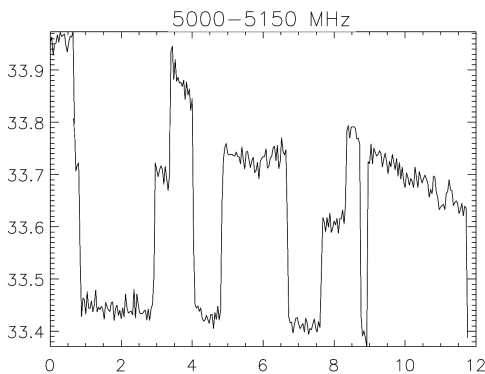

Fig. 3. Arbitrary Counts VS. sample number. Total Power observation in C-band heavily affected by radio frequency interferences (RFIs).

4. FPGAs for digital signal processing

In the next two sections we report the example of two applications where FPGAs are used as

high performance computing engines for digital signal processing.

4.1. WBLGB spectrometer

As the presence of artificial radio signals is increasing day by day, radio astronomy observations are greatly affected by the problem of radio frequency interferences, which, being orders of magnitude more powerful than radio astronomical signals, can severely compromise the scientific experiments. That's why INAF has financed a research project called "RFI MITIGATION at Italian Radio Telescopes". One of the main objective of the project has been the realization of a spectrometer used to discriminate the interfering signals within the receiver bandwidth so that those can be removed from the scientific data without compromising the overall observation.

The first spectrometer of this kind has been realized in Medicina using already present dig-

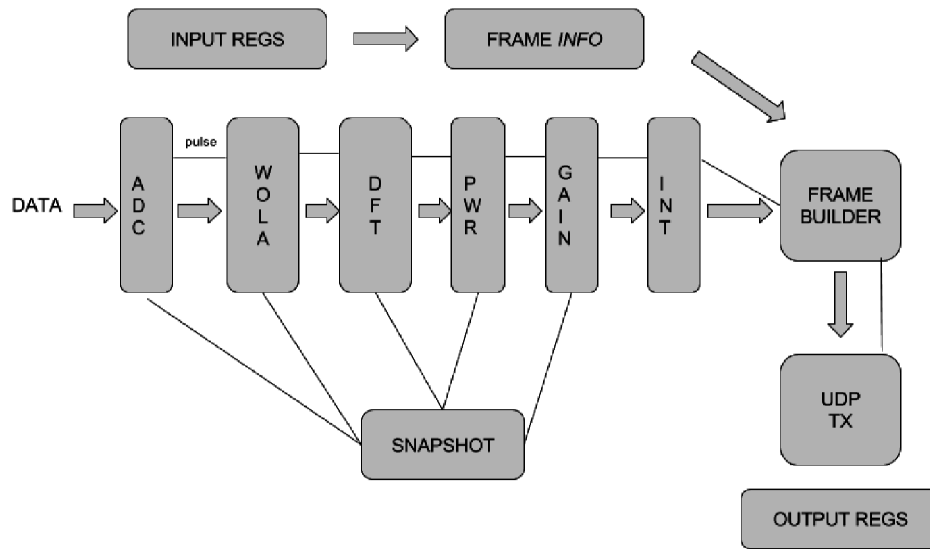

Fig. 4. Schematic diagram of the WBLGB spectrometer processing unit.

ital hardware from the CASPER consortium: in particular the **WBLGB** spectrometer has been developed on top of a Roach1 board equipped with 1Gbps analog to digital converters. The spectrometer is designed to be robust to strong signals, enabling digital downshifting of every Fast Fourier Transform stage and adopting a tunable digital gain stage. WBLGB exploits the CASPER implementation of a Polyphase Filter Bank and Fast Fourier Transform in order to achieve good channel isolation. Signal is then revealed computing the power spectrum. A tunable digital gain is applied at this stage, and the signal is then quantized at 8 bits before accumulation. The accumulation or integration stage is the final one, where revealed signals are summed up for a configurable number of samples, using block RAM on board of the FPGA. Data is then packetized in UDP frames, along with every necessary timestamp information and overflow meta-data, and is then transmitted via 10Gbps ethernet links (see Fig. 4).

Table 1. WBLGB spectrometer characteristics

Processed Bandwidth	700MHz
Frequency Bins	4096
A/D bits	8
Time resolution	1ms
CASPER board	Roach
A/D converter board	iADC
FPGA	XILINX Virtex 5

Every processing stage can be inspected in order to monitor possible digital overflows due to the strong interfering signals. As RFI can be very fast phenomena the spectrometer is designed so that it can process one spectrum each millisecond and a great attention has been given to time-stamping of data which is very accurate thanks to a PPS synchronization and on-board time flagging. The characteristics of this spectrometer are summarized in table 1.

The spectrometer is effective for its purpose as can be seen in Fig. 5 where a very

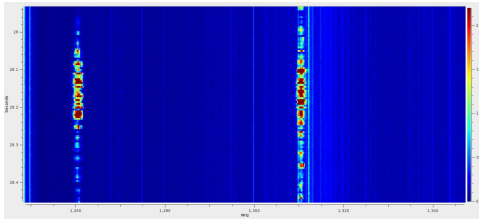

Fig. 5. Frequency VS Time spectrogram of an interfering signal produced using WBLGB spectrometer

quickly pulsing signal is correctly described in both time and frequency domains with great accuracy, successively enabling its deletion from the astronomical data set.

4.2. Medara

One of the main advantages of the CASPER community approach is the ability to share an architecture among different instruments, once it's been developed, thus exploiting the real programmability of FPGAs just as we are used with CPUs and software. This enables an optimization of hardware resources as well as of development efforts. As an example of this approach, we detail the case of the SARDARA spectrometer, developed at Sardinia Radio Telescope (SRT) on top of a Roach2 board. The SARDARA spectrometer borrows its main components from open source designs developed for radio astronomy and made available to the CASPER community via public repositories. The spectrometer presents excellent performances as detail in Table 2 and once installed at SRT, it is now being replicated at Medicina with the name MEDARA. A Roach2 board already present at Medicina site is being used for this purpose, showing how a commonality of infrastructures and similar hardware setups can benefit from the use of FPGA hardware when it comes to re-usability and cost optimization.

5. FPGAs for digital backends control

The adoption of FPGA technologies at Medicina station is indeed not only tied to dig-

Table 2. SARDARA spectrometer characteristics

Processed Bandwidth	2.0GHz
Frequency Bins	16384
A/D bits	8
Time resolution	1ms
CASPER board	Roach2
A/D converter board	ADC1x5000-8
FPGA	XILINX Virtex 6

ital signal processing applications. Since from the very first digital systems adopted at the radio telescope, FPGAs have been used in order to implement real-time control logics, which, paired with PLCs technologies, enable an efficient control of electronic instrumentations. In the following sections we give two examples of recent developments obtained using FPGAs in this way.

5.1. Total Power backend control

Total Power observations are performed in single dish radio telescopes; from a hardware point of view those mainly consist of sampling the output of a diode power detector at fixed time intervals. The samples are digitized and saved as the data stream used by astronomers. That's the case of the Total Power Backend developed at Medicina (Scalambra et al. 2013) and also used at SRT. In this backend an FPGA board "colibri" from Acme Systems, based on ACTEL A3P250 is interconnected with a SBC FOX Board G20 (ARM9 @ 400MHz legacy Linux embedded board). This system uses a multi channel Voltage to Frequency converter to acquire total power value. The FPGA is in charge of producing variable sample rate and to embed UTC epoch information into data stream.

5.2. Analog pulsar filter bank sampling

The same hardware setup of the Total Power backend has been used along with the analog pulsar filter bank back-end. The system consists of 1024 channel digitized at 1 bit, at each sample, all 1024 channel are stored in 16 bit words, into one memory buffer. In the meantime the CPU has access to the second mem-

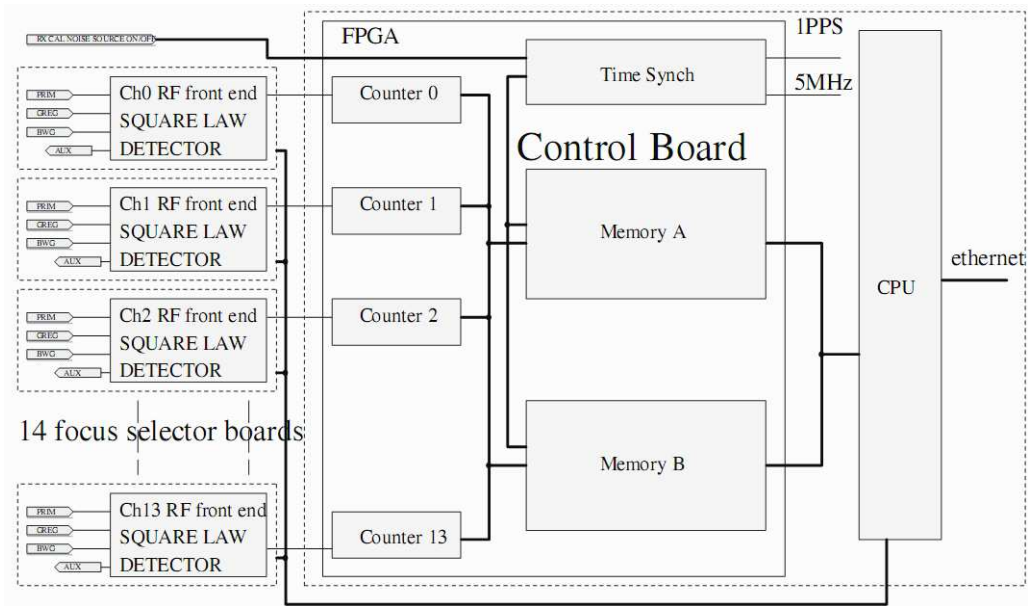

Fig. 6. Schematic diagram of the pulsar back-end.



Fig. 7. Colibri board from Acme Systems connected to a SBC FOX Board G20.

ory buffer and transmits the stored samples via ethernet. The FPGA implement the data bus and the mux control from digitizer, the epoch counter and UTC info, the sample rate generator, the dual memory buffer management and the bus interface towards the cpu board.

6. Conclusions

As radio astronomy applications involve an always increasing signal bandwidth and computational complexity, FPGAs have demonstrated to provide a cost effective solution in a number

of cases. We foresee an always greater adoptions of such technologies, also considering that FPGA architectures are being targeted by software compilers and libraries which would greatly increase productivity in terms of development time and complexity. If for control applications we have a number of options when it comes to FPGA boards, and these are all almost equivalent, when it comes to high power computing there is still lack of industrial COTS components. The CASPER consortium strives to provide a valid alternative, producing high end products which are demonstrating to be effective and durable. At Medicina radio telescope future developments will involve the porting of the WBLGB design on top of a Roach2 board and the scientific commissioning of the Medara spectrometer, which will be fully integrated in our control system.

References

- Orlati, A., et al. 2016, Proc. SPIE, 9913, 991310
- Righini, S., Orlati, A. and Bartolini, M. 2013, Observing at Medicina with ESCS 0.3, IRA internal report 480/14,

- <https://www.ira.inaf.it/Library/rapp-int/480-14.pdf>
Scalambra, A., Cattani, A., Fiocchi, F and Maccaferri, A. 2013, PCB FS-TP - Focus Selector e Total Power back-end, IRA internal report 473/13,
- <https://www.ira.inaf.it/Library/rapp-int/473-13.pdf>
Various Authors 2009, CASPER collaboration for astronomy signal processing and electronic research, website, <https://casper.berkeley.edu>