



The SIMBOL-X hard X-ray optics

G. Pareschi (on behalf of the SIMBOL-X collaboration)

INAF-Osservatorio Astronomico di Brera, Via E. Bianchi 46, 23807 Merate, Italy

Abstract. The SIMBOL-X formation-flight X-ray mission will be operated by ASI and CNES in 2013. Thanks to the formationflight architecture, it will be possible to operate a long (20 m) focal length grazing incidence optics module made of 100 confocal multilayer-coated Wolter I shells. This system will allow us to focus for the first time X-rays over a very broad energy band, from 0.5 keV up to 80 keV and beyond, with more than two orders of magnitude improvement in angular resolution and sensitivity compared to non focusing detectors used so far. In this paper, the SIMBOL-X optics design, technology and implementation challenges will be discussed.

Key words. Hard X-ray telescopes, X-ray astronomical optics, X-ray multilayer mirrors

1. Introduction

SIMBOL-X (Ferrando et al. 2004; Pareschi and Ferrando 2006) is a hard X-ray mission based on a formation flight architecture, operating in the 0.5 – 80 keV energy range, for which a comprehensive Phase A study is being jointly carried out (at the time being almost concluded) by CNES and ASI, with a large participation of Italian (INAF), French (CEA, CNRS, APC) and German (MPE, IAAT) scientists. SIMBOL-X makes use of a long (20 m) focal length multilayer-coated X-ray mirrors, to focus for the first time X-rays with energies above 10 keV. The resulting improvement is of some three and two orders of magnitude in sensitivity and angular resolution respectively compared to the no focusing techniques used so far (basically collimated detectors or large open angle coded mask systems). The

mission will be operated on the second half of 2013, by means of a Soyuz rocket launched from Kourou. The SIMBOL-X revolutionary instrumental capabilities will allow us to elucidate outstanding questions in high energy astrophysics, related in particular to the physics and energetic of the accretion processes ongoing in the Universe. It will perform a census of black holes on all scales, achieved through deep, wide field surveys of extragalactic fields and of the Galactic centre, and the to the acceleration of electrons and hadrons particles to the highest energies. The SIMBOL-X optics is based on classical Wolter I mirrors, to focus X-rays onto a focal plane detector system. The gain in terms of maximum observable energy is achieved by the combination of a long focal length (20m, i.e. ≈ 3 times larger than XMM-Newton) and the use of broad-band multilayer Bragg reflecting coatings (su-

permirrors). Since the large focal distance cannot fit in a single spacecraft, the mirror and detectors will be flown on two separate spacecrafts, using a formation flying configuration. In the following sections the main scientific and technical requirements related to the SIMBOL-X optics realization, together with the technological issues to be tackled, will be reviewed.

2. The mirror technology and issues

The SIMBOL-X optics module will be based on pseudo-cylindrical monolithic Ni electroformed mirror shells with Wolter I profile. The adopted technology was already successfully used for making the gold coated soft X-ray mirrors of the BeppoSAX, XMM-Newton and Jet-X/Swift missions (Fig. 1). This approach, developed in the past two decades in Italy by the INAF-IASF (Milano) and INAF-Osservatorio Astronomico di Brera in collaboration with the Media Lario Technology company (www.medialario.com), is well consolidated. The industrial readiness for production is very high, being a number of the equipments (e.g. the lapping and metrology machines for mandrels, the electroforming baths, and the vacuum chambers for the gold coating deposition) already available from past projects (Vernani et al. 2008). The diameter of the outermost mirror shell will be 65 cm, which is close to the maximum size allowed with the present mandrel polishing technology (70 cm). Just a few modifications of the process will be implemented:

- the SIMBOL-X hard X-rays mirrors will rely on a very large focal length (20 m), allowed by the formation flight architecture. The integration equipments based on optical/UV at present available at Media Lario Technologies can fit a focal length just ≤ 8 m and, therefore, they need to be refurbished for SIMBOL-X.
- the SIMBOL-X mirror shells will make use of multilayer reflecting coatings,



Fig. 1. Mirror shells and mandrels developed for making the X-ray optics module aboard Swift.

instead of the usual Au layer (as e.g. for XMM) or the Pt layer proposed in the preliminary SIMBOL-X study. The use of broad-band multilayer reflecting films not only will make possible to rely on a much larger FOV, but also extends the operative range up to 80 keV and beyond.

- Due to the need of maintaining the weight as low as possible, the Ni walls will be much thinner than the XMM mirror shells ($\simeq 2$ less). At this regard, a new integration procedure (already tested with success) will be implemented with the scope of maintaining good imaging performances, compliant with the top level requirements, even if the Ni shells will be much thinner and floppy than for past missions.

Regarding the multilayer coating, it will be applied by adding an additional step to

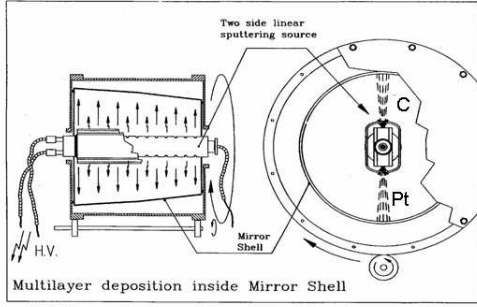

Fig. 2. Scheme of the process, based on linear DC magnetron sources, to apply the multilayer coatings onto the surface of mirror shells.

the usual Ni replication process (see Fig. 2). Once that the gold-coated Ni mirror shell has been replicated from the mandrel, the multilayer film will be grown onto the internal surface of the shell by using a two-targets linear DC magnetron sputtering system, following the process developed ad hoc at the SAO-CfA for monolithic pseudo-cylindrical shells (Romaine et al. 2006). After a consolidation of the process in view of the SIMBOL-X optics implementation, a multilayer coating facility for production will be installed at Media Lario.

The new assembly approach for thin floppy mirror shells is based on the use of two stiffening rings, to be applied at the top and bottom of each mirror element to restore an acceptable roundness profile and to handle the shells during the integration in the spiders (Basso et al. 2008). The two rings will be removed once that the shell is fixed by glue to the two spiders. In order to maintain a sufficient rigidity, their design foresees a number of arms (24) larger than usual. Moreover, also the use of new materials for the mirror walls electroforming are being studied for SIMBOL-X, in order to reduce the deformations during the shell separation from mandrel and handling. At this scope particularly promising is the implementation of the Ni-Co alloy (already investigated by NASA-MSFC for the development of the Constellation-X optics) instead of pure Ni used so far, since it

presents more performing mechanical parameters; in particular, the micro-yield is $\simeq 5$ times better, and the elasticity modulus $\simeq 10\%$ higher.

It should be noted that another critical point of the SIMBOL-X mirror production concerns the superpolishing process for mandrels. The surface profiles should have intrinsic errors similar to XMM (6 arcsec HEW on average) but with a very low roughness level, in order to minimize the scattering effects at high energies (a typical slope of the PSD of ~ 2 in the range between 200 and $0.1\ \mu\text{m}$ is needed (Spiga et al. 2008)). It has been already proven at INAF-OAB that these parameter can be achieved by using classical grinding and polishing techniques, but with a quite slow working time. In order to speed up the production time, the use of new figuring and lapping technologies are under investigation at Media Lario, based on the use of the single point diamond turning machining and the magneto-rheological finishing.

3. The scientific requirements versus optics design

During the Phase A study the scientists of the Joint Scientific Mission Group, coordinated by ASI and CNES, worked out a document of top level requirements for SIMBOL-X, to be fulfilled for a complete compliance with the core scientific objectives of the mission. In this context, a number of parameters directly concern the capabilities of the optics module, as reported hereafter.

- On axis Effective Area
 $\geq 100\ \text{cm}^2$ at 0.5 keV, $\geq 1000\ \text{cm}^2$ at 2 keV, $\geq 600\ \text{cm}^2$ at 8 keV, $\geq 300\ \text{cm}^2$ at 30 keV, $\geq 100\ \text{cm}^2$ at 70 keV, $\geq 50\ \text{cm}^2$ at 80 keV (goal)
- Angular Resolution
 ≤ 20 arcsec (HPD, requirement), $E < 30$ keV ≤ 15 arcsec (HPD, goal), $E < 30$ keV ≤ 40 (HPD) @ $E = 60$ keV (goal)
- Field of View
 ≥ 12 arcmin (diameter) @ 30 keV

Table 1. Angular resolution at 30 keV for past hard X-ray missions and SIMBOL-X

Experiment	Year	Imaging Technique	Angular Resolution	Parameter
SAX-PDS	1996	Rocking Collimator	≥ 3600 arcsec	collimator pitch
INTEGRAL-IBIS	2002	Coded Mask	≥ 720 arcsec	mask element pitch
HEFT (balloon)	2005	Multilayer Optics	≥ 90 (30) arcsec	HEW (FWHM)
SIMBOL-X	2013	Multilayer Optics	15 ($\simeq 5$) arcsec	HEW (FWHM)

Compared to past hard X-ray missions (Tab. 1), SIMBOL-X will have unprecedented imaging capabilities. It should be noted that the very demanding requirement in terms of angular resolution is mainly dictated by the exigency of avoiding problems of confusion among weak sources in deep surveys and to solve the puzzling problem of the hard X-ray emission from the Galactic Center region.

4. The optics design

The optics configuration of the SIMBOL-X optics has been addressed in the context of the on-going study Phase A study. After performing a trade-off aiming at a design compliant with the specifications but compatible with the mass constraint of the mission (the limit for the whole optics assembly, including structures and subsystems, was ≤ 480 kg) we arrived at the set of parameters reported in Tab. 2.

The mirror shells, after the integration, are kept fixed to the mechanical case by the use of two spiders, a solution already adopted for BeppoSAX and JET-X/Swift (see Fig. 3). The weight of the sole mirror shells is 287 kg; the whole optics module (including also case, spiders, adapter, star trackers and other minor subsystems) is 413, plus a 10 % contingency. The theoretical on-axis effective area of the mirror shell is given in Fig. 4, while the expected field of view as a function of the photon energy is shown in Fig. 5. The overall telescope effective area is not only affected by the spider vignetting, but also other factors contribute

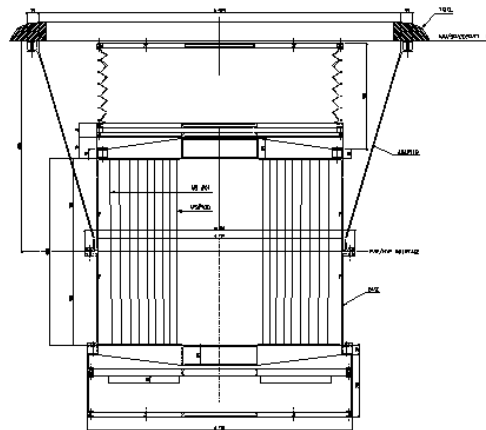
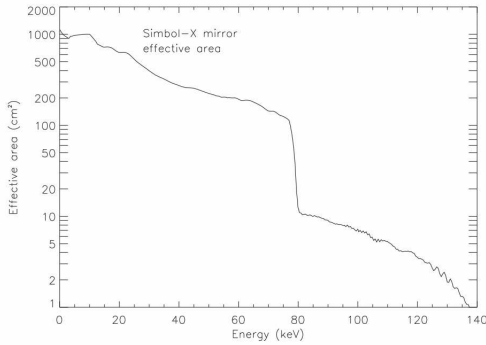

Fig. 3. Drawing of the SIMBOLX optics module, including subsystems (pre-collimators and particle diverters); just a few representative mirror shells are reported.

to its reduction. The most important ones are the quantum efficiency of the detectors, the presence of filters to protect the focal plane from optical stray-light, the area lost to the detector segmentation and, finally, the presence of two Al coated thermal blankets at the optics top and bottom, implemented to make easier the thermal control of the system; at this regard it should be noted that the temperature of the optics should be between 17 and 22 °C, with a gradient ≤ 1 °C. The resulting effective area, after taking into account all these effects, is depicted in Fig. 6.

Table 2. SIMBOL-X Optics Parameters

Number of modules	1
Geometrical profile	Wolter I
Number of nested mirror shells	100
Reflecting coating	Pt/C multilayer (200 bi-layers)
Focal Length	20000 mm
Total Shell Height	600 mm
Plate Scale	10.3 arcsec/mm
Material for the mirror walls	Electroformed Ni (or Ni-Co)
Min-Max Top Diameter	260 to 650 mm
Min-Max angles of incidence	0.18 – 0.23 deg
Min-Max wall thickness	0.2 to 0.55 mm
Angular resolution HEW (goal)	20 (15) arcsec
Mirror shell weight	287 kg
Total optics module weight	413 kg
Additional mass contingency	40 kg

**Fig. 4.** SIMBOL-X expected onaxis effective area; the only vignetting due to the spiders arms is taken into.

5. Preliminary error budget tree

A preliminary budget of the errors determining the worsening of the HEW is reported in Tab. 3 for both requirement and goal levels. This evaluation has been done on the basis of the experience from previous projects (in particular XMM) and the preliminary results of the on-going assessment study. Apart from the errors concerning the mirror shells production and integration, particular attention should be given to the problem of the focal length uncertainty (see Fig. 7), since different sources can contribute to this effect. Indeed a first

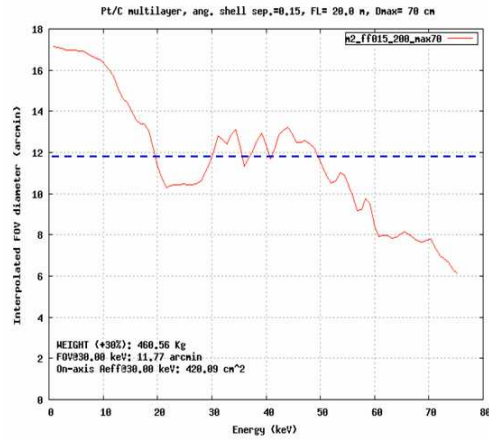
**Fig. 5.** Field of View (diameter at 50 % vignetting of the on-axis effective area) as a function of the photon energy. The cut determined by the size of the focal plane detectors is also reported.

issue comes from the use of two detectors (the LED and the HED) in series with the ideal focal position fall in between; for this reason the distance between the two detection planes cannot be larger than a couple of cm. Another problem is represented by the dithering along the optical axis of the detector spacecraft with respect to the mirror spacecraft; the possible oscillations should

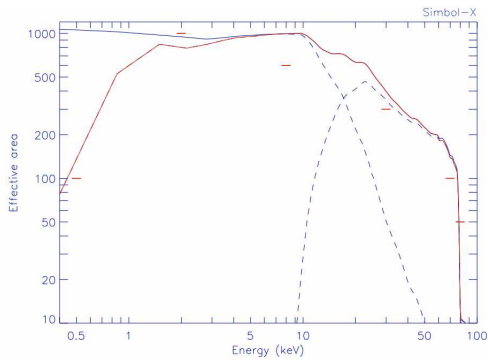

Fig. 6. SIMBOL-X onaxis effective area evaluated taking into account all the effects contributing to its decrease. The levels imposed by the mission requirements are also reported.

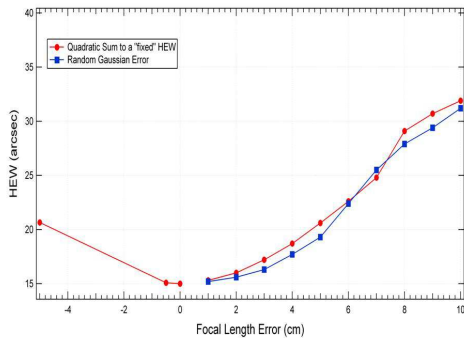

Fig. 7. HEW increase due to the focal length error, assuming an intrinsic optics HEW of 15 arcsec (the two profiles represent different approaches for the calculation).

be also kept at a level of a few cm at most.

6. Conclusions

The SIMBOL-X focusing optics will allow us for the investigation of the hard X-ray (≥ 10 keV) sky with unprecedented flux sensitivity and imaging capability. The formation-flight architecture makes possible the implementation of long focal length

Table 3. Preliminary error budget tree for the optics angular resolution; since the errors are independent to each-other, the total budget comes from their quadratic sum.

Error Source	Requirement (arcsec)	Goal (arcsec)
Mandrel profile	7	6
Mirror shell repl.	8.5	6
Single shell integr.	6.5	6
Xray scattering	14.8	10
Focal length err.	3	2
N shells integr.	2	2
Thermal deform.	2	1
Contingency	1.5	2.9
SQUARE SUM	20	15

(20 m) multilayer-coated mirrors in Wolter-I configuration, with an aperture similar to that of XMM but with an effective area profile extended from 0.5 keV to beyond 80 keV. The technology adopted for the fabrication of the SIMBOL-X optics will be the well consolidated Ni electroforming replication, with some changes. A technological assessment study is currently on going, aiming at getting the technology ready for starting the activities of the flight optics module production on 2009.

References

- Basso, S. et al. 2008, Mem SAIt, present issue
- Ferrando, Ph. et al. 2004, SPIE Proc., 5168, 65
- Pareschi, G., and Ferrando, Ph. 2006, Exp. Astr., 34P
- Romaine, S. et al. 2006, SPIE Proc. 6266, p. 62661C
- Spiga, D. et al. 2008, Mem SAIt, present issue
- Vernani, D. et al. 2008, Mem SAIt, present issue