



The Processing of Altimetric Data (PAD) System for Cassini RADAR

G. Alberti¹, C. Catallo², L. Festa¹, E. Flamini³, R. Orosei⁴, C. Papa¹, G.
Picardi⁵, R. Seu⁵, F. Spataro², and G. Vingione¹

¹ Consorzio di Ricerca Sistemi di Telesensori Avanzati, Via John Fitzgerald Kennedy 5,
I-80125 Napoli, Italy

² Alcatel Alenia Space, Via Saccomuro 24, I-00131, Roma, Italy

³ Agenzia Spaziale Italiana, Viale Liegi 26, I-00198 Roma, Italy

⁴ Istituto Nazionale di Astrofisica, Istituto di Astrofisica Spaziale e Fisica Cosmica, Via del
Fosso del Cavaliere 100, I-00133 Roma, Italy

⁵ Università di Roma "La Sapienza", Dipartimento INFOCOM, Via Eudossiana 18, I-
00184 Roma, Italy

e-mail: alberti@unina.it

Abstract. This paper describes the Cassini RADAR PAD System, which has been designed and developed in the frame of Cassini-Huygens, a joint NASA/ESA/ASI mission to Saturn and its moons, responding to ASI request to process the data collected by the Cassini RADAR Altimeter. The PAD System contains the HW and SW operational tools necessary to evaluate the instrument performances, to process the raw data, and finally to visualize digital maps of Titan's surface by using the data acquired by the Cassini RADAR during close flybys of Titan. Titan, the largest moon of Saturn, is the only satellite in the solar system to host an appreciable atmosphere. The smoggy haze that completely envelops the satellite is composed mostly of nitrogen, aerosols and a variety of hydrocarbons, produced as atmospheric methane is destroyed by sunlight. To date, many scientists have speculated that the surface could probably contain solid, liquid and muddy material creating features such as lakes, seas, or rivers, and it should be mostly coated with sticky brown organic condensate rained down from the atmosphere. The PAD System, actually installed and operated at Alcatel Alenia Space Italia premises in Rome will be able to grant the provision of altimetric data for at least the nominal 4-years mission lifetime (i.e. 45 envisaged flybys of Titan).

Key words. Astronomical data bases: miscellaneous – Techniques: radar astronomy – Planets and satellites: individual: Titan

1. Introduction

The general objective of the Cassini RADAR experiment is to carry out the first-order ge-

Send offprint requests to: G. Alberti

ological reconnaissance of Titan's surface and to derive a quantitative characterization of the surface. The approach is to use microwave radiation to penetrate opaque atmosphere, map the surface, and, combining RADAR data

with the data from the Cassini optical remote sensing instruments, obtain a comprehensive understanding of Titan's physical condition (Matson et al. 2002). In order to study the surface properties and processes of Titan, the spacecraft will make a number of close flybys during its 4-year nominal mission. During these flybys, Cassini RADAR and other instruments onboard the spacecraft will conduct intense observations, in order to achieve the scientific goals. The first targeted fly-by of Titan (Ta) occurred on Tuesday, October 26, 2004 at 15:30 UTC (Elachi et al. 2005).

While operating as an altimeter (ALT mode), the instrument will be able to measure surface elevations along the sub-satellite ground tracks. At an inhospitable temperature (around 90 K), the chemistry that drives surface processes is fundamentally different from Earth's: it is methane to perform many of the same functions on Titan that water does on Earth. As a consequence, the mapping of Titan is an especially challenging puzzle, because the most likely constituent materials in this chemical and temperature regime are likely to exhibit different scattering properties than at Earth and Venus, the only other worlds mapped by spaceborne radars (Elachi et al. 2005).

In the frame of the Cassini RADAR Program, the Cassini Processing of Altimetric Data (PAD) System has been conceived in order to process the data collected by the Cassini RADAR, while operating as an Altimeter. The integrated software application, developed by CORISTA and Alcatel Alenia Space Italia under ASI contract, offers all the specific instruments needed to process, manage, visualize, archive and disseminate the scientific products containing all the retrieved information about the Titan surface topography, starting from the raw data as provided by JPL/NASA.

The height retrieval functionality, core of the altimetric processing, is performed by using implemented algorithms which are based on *ad hoc* developed mathematical techniques necessary to simulate analytically the average return power waveform, as obtained from the received signal, in order to cope with the particular operating conditions, and with the expected occurrence of off-nadir measurements.

In the following, after a brief introduction concerning the Cassini RADAR, an overview of the PAD System architecture in terms of implemented functionalities, component applications and system design will be given.

2. The Cassini RADAR

The Cassini RADAR is a multimode microwave instrument that uses the 4 m high gain antenna (HGA) onboard the Cassini orbiter. The instrument operates at Ku-band (13.78 GHz or 2.2 cm wavelength) and it is designed to operate in four observational modes (Imaging, Altimetry, Backscatter and Radiometry) at spacecraft altitude below 100.000 Km, on both inbound and outbound tracks of each hyperbolic Titan flyby, and to operate over a wide range of geometries and conditions (Elachi et al. 1991). The instrument has been designed to have a wide range of capabilities in order to encompass a variety of possible surface properties.

From signal to noise and data rate considerations, the ALT mode is planned to operate at S/C altitudes between 4000 and 9000 Km, approximately from 16 min before the closest Titan approach of each Titan flyby until 16 min after the closest encounter. During such operation, the radar will utilize the central, nadir-pointing antenna beam (Beam 3, a circular beam 0.350 across) for transmission and reception of chirp pulse signals at a system bandwidth of 4.25 MHz (Elachi et al. 1991, 2004).

The Altimeter operates on "burst mode", similar to the imaging mode. When the ALT mode is executed, bursts of frequency modulated pulse signals (chirp pulses) of 150 s time duration and at 5 MHz bandwidth will be transmitted in a Burst Period (the Burst Repetition Interval is 3333 ms). The transmit time varies from 1.4 to 1.8 s. The number of pulses transmitted in each burst will vary throughout a single flyby pass.

The collected altimeter measurements are expected to have horizontal resolutions ranging between 24 and 27 Km, and a (final achievable) vertical resolution of about 30 m. In addition to the limitation due to the intrinsic ver-

tical resolution, the accuracy in estimating the relative surface elevation (that is, the change in local surface elevation relative to a reference datum) depends also on the topographic relief of the surface as well as on the knowledge of the spacecraft's ephemeris and attitude. An estimate of such accuracy is between 100 and 150 m.

3. The Processing of Altimetric Data (PAD) System

As part of the Cassini RADAR Program, ASI required to process and exploit the Cassini altimetry data, by means of an *ad hoc* developed system: the Cassini RADAR PAD. The implemented system contains the HW and SW tools necessary to:

- receive and elaborate the Cassini RADAR Altimeter instrument raw data sets
- generate the science data products from the received Cassini RADAR Altimeter data sets
- archive and manage the science data products within the system.

The system is able to manage BODP files supplied by JPL. Basically, these are data sets at various stage of processing, organized as time-ordered records for each burst. They are fixed header length and fixed record length files, compliant to PDS standards. The header is an attached PDS label. According to SIS, BODP products come in three different record formats:

- Short Burst Data Record (SBDR)
- Long Burst Data Record (LBDR)
- Altimeter Burst Data Record (ABDR).

The SBDR is produced for every Titan flyby, and it is divided into three consecutive segments from three different levels of processing (Engineering, Intermediate Level and Science Data Segments) containing radar telemetry, timing and spacecraft geometry information and all relevant scientific data. The LBDR is simply a SDBR which also contains sampled echo data. The LBDR data for altimetry supplied by JPL to ASI will contain only

basic engineering unit conversions and geometry calculations. The ABDR data is the same as the SBDR, except that it includes the altimeter profile. The ABDR file is generated from the altimeter processor and it can be furthermore used to perform additional altimetry processing.

The physical architecture of the PAD System is reported in Fig. 1. It is composed by several software components distributed on two operating system platforms. The server platform, supported by a Linux operating system, hosts the local data archive and acts as the domain server, while the client platform, supported by a ©Windows XP Professional operating system, hosts the data processing subsystem. On the server platform, the logical component of the local data archive is the distributed file system: the local archive is accessed as a network drive by the data processing subsystem. The server handles the definition and the authorizations of the domain's groups and users to access the distributed resources. On the client platform, the data processing subsystem is represented by the Cassini RADAR PAD application, installed with same functionalities on each workstation.

The core of the DPS is represented by processing algorithms and tools developed in a ©Matlab environment. Each tool is provided with a user-friendly GUI, which allows users to exploit all implemented functionalities. The architectural design of PAD tools is shown in Fig. 2. The core tools are integrated into a framework, which is a standard ©Windows application written following the design specifications and guidelines of the official guidelines for user interface developers and designers.

4. PAD Components

The PAD System actually can be divided into six main logical components, briefly described in the following:

4.1. PAD Framework

The main functionality of the PAD Framework software is to give users a global vision of the status of all the operations that can be made

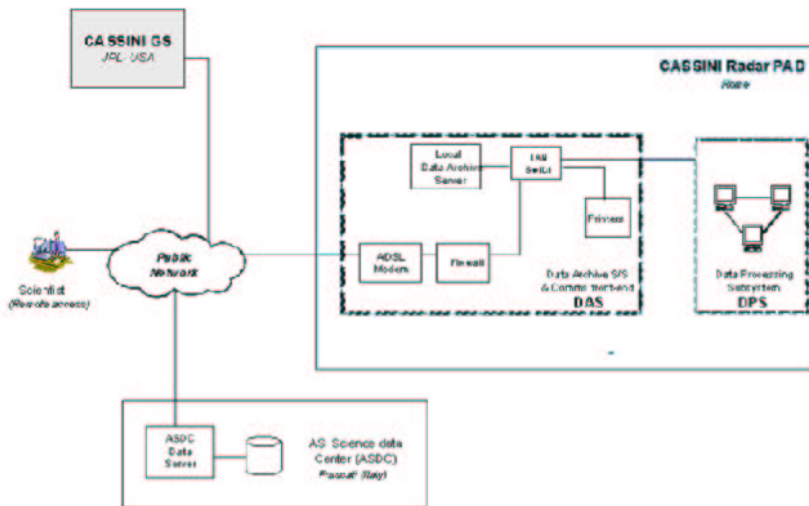

Fig. 1. PAD System Physical Architecture

on the BODP files within the Cassini RADAR PAD. It provides easy access to all system functionalities. Users can select the flyby to operate and start any operation available for the processing of telemetry files.

4.2. PAD File Manager

The PAD File Manager is the software component that allows users to import the PDS telemetry files into the Local Archive, and to deliver the output ABDR products to the scientific community.

The LBDR data retrieval can be executed through the JPL secure HTTPS site, or from any file system location indicated by the user. The delivery functionality can publish the ABDR file on a public FTP repository and/or copy it to a writable portable transfer media.

4.3. PAD Data Publisher

The PAD Data Publisher is the software component containing all the commands and the methods that allow users to forward the ABDR files to the Cassini Ground System repository located at JPL. The produced ABDR file is not physically sent nor moved to the

Cassini Ground System repository located at JPL. Once the PAD File Manager has published the ABDR files to the public FTP repository, the scientific community receives an e-mail notification to access the password protected repository in order to download the new available file.

4.4. ABDR Production Tool

The off-line ABDR Production Tool (PT) retrieves the input LBDR files by managing a list of LBDR files locally stored, allowing user to select the input file. After interactive selection of the LBDR file to be processed, the tool proposes to start the creation of subsets of the input LBDR product (intermediate PT Files) each containing only data records pertinent to one of the *active* Cassini RADAR operational modes, i.e. Altimeter, SAR and Scatterometer mode. These files are created for internal use and stored into the local archive in both binary and ASCII format, in order to be accessed by SLT.

The PT allows user to perform the generation of the ABDR product starting from the selected LBDR file. Moreover, user is allowed

The SLT Tool allows users to specify the default processing parameters by using a Configuration File containing:

The SLT provides several auxiliary functionalities that allow the user to obtain the complete monitoring of both processing and results. On user request, the SLT provides 2-D or multi-plots of S/C and RADAR ancillary data, processing results and algorithm configuration. All the results can be exported (i.e. printed/saved) by user. In addition, on user request, a report file in xml format is generated containing all the results produced by the SLT, e.g. relevant processing parameters, MLE procedure results, relative elevations of Titan's surface vs. along-track distance (i.e. topographic profiles), altimeter waveforms vs. range bins, ancillary data (e.g. observation geometry and orbital parameters vs. time, instrument data, etc.), surface parameters vs. along-track distance, etc. It will be used by scientists for further validation of data, which is propaedeutical to ABDR production.

4.6. Map Tool

The off-line PAD Map Tool (MT) is a graphical application that allows users to visualize and navigate through Titan's 2D and 3D maps, finalized to the analysis of their informative content, as immediate instrument of interpretation of scientific data. From the point of view of scientific surveying, altimetric maps could be confronted and joined with maps obtained by radiometric surveys and with the analysis made by other instruments onboard the Cassini Spacecraft, in order to provide a global vision, as far as it is possible, of the characteristics of Titan's surface.

The purpose of MT is the production of altimetric regional maps obtained by visualization of sub-satellite ground-tracks and overlapping of data collected along tracks to a pre-existent map of Titan, over the region illuminated by the Cassini RADAR in high-resolution ALT mode, for each Titan fly-by. Hence, Titan's maps represent the final results

of data processing. The realization of the altimetric map can be accomplished by referencing the radar altimetry profile with respect to the surface of Titan.

The Titan's altimetric maps are generated starting from SBDR, LBDR and BIDR data files, and from output data produced by the SLT (e.g. the topographic profile with information about the surface slope, etc.) which could be superimposed to referenced images of Titan surface in a given projection. The content of SBDR, LBDR and BIDR data files is extracted by means of a *Data Production Utility*, which saves all relevant information needed to produce MT datasets (map internal files) containing satellite geometry, Scatterometer, Radiometer and SAR data, which becomes then available to Map Tool for visualization. The SLT output data needed to MT procedures execution are retrieved from the local archive or database. All maps produced by the Map Tool are stored into the local archive, for further distribution.

5. Conclusions

The Cassini RADAR Processing of Altimetric Data System has been presented. The system is actually installed and operated at Alcatel Alenia Space Italia premises in Rome. An overview of the main functionalities has been provided, in order to show all the potentiality of the system to serve as a useful tool for the scientific community to support the analysis and validation of Cassini RADAR Altimeter data. Actual capabilities could be undoubtedly expanded by future system's evolutions.

References

- Elachi, C. et al. 1991, IEEE Proceedings, 79, 867
- Elachi, C. et al. 2004, Space Science Reviews, 115, 71
- Elachi, C. et al. 2005, Science, 308, 970
- Matson, D. L. et al. 2002, Space Science Reviews, 104, 1